

See our
Online Catalogue
 at www.groundsmanindustries.com

Internet



www.groundsmanindustries.com
info@groundsmanindustries.com

Telephone



UK : 028 2766 7049
 Int : +44(0) 28 2766 7049

Fax



UK : 028 2766 6855
 Int : +44(0) 28 2766 6855

Address



30 Ballybrakes Road
 Ballymoney
 Co. Antrim
 Northern Ireland
 United Kingdom
 BT53 6LG

Uk & Ireland Distributor's

Ireland & Scotland
Groundsman Industries
 Phone +44(0) 28 2766 7049
www.groundsmanindustries.com

England & Wales
Synergy Products Ltd
 Phone +44(0) 1380 828 337
www.synergyproducts.co.uk

Other Country's

Please See The Links Page
 On Our Web Site

Groundsman Product Catalogue



Page 1	Index
Page 2	Turf Aerators
Page 3	Aerator Attachments
Page 4 & 5	Turf Retainers
Page 6–13	Tines & Holders
Page 14	Core Collection
Page 15 & 16	Turf multi Cutters
Page 17	TC HYD Attachments
Page 18 & 19	Cutter Implements & Blades

This catalogue is a summary of the Groundsman Product Range. Further information and technical specifications are available on request. See front and back covers for contact details. Please visit our website www.groundsmanindustries.com where you will find lots of information, downloadable PDF brochures and short video clips of the machines working.

Turf Aerators

Models 345MD / 345HD

GROUNDSMAN 345 Models are sealed bearing crank driven plunge action machines available in HD (heavy duty) and MD (medium duty). They are front wheel drive and have 3 tining arms and an operating width of 45cm(18 inches). They are fitted with a Honda 6.5hp petrol engine and 500x4 pneumatic tyres.



Model 460HD

The GROUNDSMAN 460HD is a wider version of the 345 range. It has 4 tining arms and an operating width of 60 cm (24 inches). They are fitted with a Honda 8hp petrol engine and 650x6 pneumatic tyres. It is only available as a heavy duty version.



Model 460SDR

The GROUNDSMAN 460 SDR is the top of the range pedestrian aerator. It has the same 4 arm heavy duty aeration mechanism as the 460HD but with two aeration speeds, rapid transport and power steering. Engine and tyres are the same size as the 460HD.



Model 8120CTM

The GROUNDSMAN model 8120CTM is an 8 arm 120cm (48") swath compact tractor mounting machine. Minimum tractor requirement of 18 to 20 HP. Its modular design uses two 4 arm heavy duty aeration units. This machine has been designed to accept the unique GROUNDSMAN Flexblade Core Collector attachment which enables you to Core and Collect in one pass.



Model 12180TM

The GROUNDSMAN model 12180TM is a 12 arm 180cm (60") tractor mounting machine. Minimum tractor requirement is 28 to 30 HP. As with the 8120, it is modular using four 3 arm heavy duty tining units. This machine can also be used to core and collect in one pass with the Flexblade Core Collector attachment.



Aerator Attachments

Windrow Attachment

Model No: WA3 & WA4

A windrow attachment is available for all Groundsman Pedestrian operated Turf Aerators. This attachment gathers the soil cores into a centre row for easier collection. It is attached to a slotted bracket to each side of the rear flap and secured by two spring pins. An adjustable lift chain pulls the attachment clear of the ground when the machine is raised.



Core Collection

Models: FCC8 & FCC12

This patented attachment is available for the Groundsman Tractor Mounting Turf Aerator models 8120CTM and 12180TM. Cores are dumped automatically when the machine is raised. A series of soil or core piles will be left on the edge of the green or aerated area. The Collector has the capacity to collect these piles into one collective pile, eg, to a selected spot away from play. This attachment can save many hours of manual work or a follow-up operation with heavy cumbersome equipment. It is clean and efficient with over 60% of the cores entering the Collector without touching the ground. The remainder are scooped cleanly from the surface by a series of platelets which follow the contours acting like shovels.



Core Collection is on Page 14

Surface Roller Attachment

Model No: SR3 & SR4

The surface roller attachment is available for all the Groundsman Pedestrian Turf Aerators. It is used to smooth out the surface of fine turf when needle tining or spiking is performed. This implement can help prevent scalping around the hole parameter on the follow up cutting especially if the mower is set very low. It attaches the same way as the Windrow.



Surface Iron

Model No: RTK8120 & RTK12180

The surface Iron effectively performs the same task as the Surface Roller Attachment on the Pedestrian Turf Aerators. This system works in the same principal as the Flexblade Core Collector except the leading edge is turned upward like a ski which follow the surface contours. This system is flexible on the surface of rolling terrain making it more effective than a roller on the wider Tractor Mounting machines. It is used, as with the roller, to smooth out the surface when needle tining or spiking.



Tie Down Bracket

Part No: GI269

A tie down bracket is available to give convenient and secure tie down locations between the front and rear axles on the pedestrian operated Turf Aerators. The brackets come complete with mounting bolts and bolt holes are provided on the chassis sides. These brackets will prove invaluable when transporting the machines between sites.

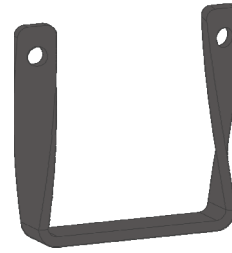

Turf Retainers

Turf Retainer Pedestrian Mount

Model No: TRR3, TRR4 & TRR4S

The Elliptical Plunge Action tining mechanism on the Groundsman range of surface aerators causes very little surface lifting. However, in circumstances where the roots are particularly shallow, turf retainers are available for all pedestrian and tractor mounting Aerators. Holes are provided in the chassis sides to bolt the mounting bracket to finger holders and a spring loaded mounting bar provides a quick attachment for the finger-bar holders which are available for Twin, Triple and Quad Holders.

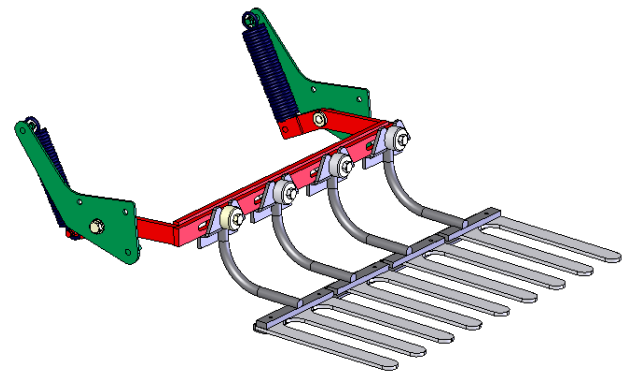

Turf Retainer Rack Tractor Mount

Part No: TRR8 & TRR12

The Rack is required if Turf Retainers are to be used. It consists of a box section member which attaches to the roller leg bracket on the 8120 and 12180 Tractor Mounting Turf Aerators. This rack spans the width of the machine just in front of the roller. Spring loaded brackets extend over the roller rearwards onto which the Turf Retainer Holders are bolted in pairs. This system allows the retainers to follow the contours of the surface while maintaining a constant pressure on the turf to prevent lifting. The rack is supplied with Blank Retainer Holder Flanges to keep the clamp bolts secure when retainers are not being used.

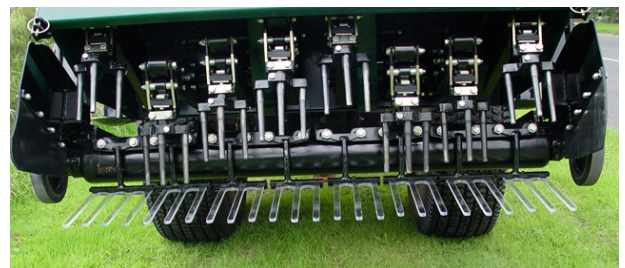

Turf Retainer Holders

Part No: TRH & TRHW

Turf Retainer Holders are required to hold the plastic retainer sections. One wide holder is required in each set. The model 8120 machine requires 8 retainers i.e, 7 standard and 1 wide. The model 12180 machine requires 12 retainers i.e, 11 standard and 1 wide. The Holders have a bolted bottom plate which clamps the plastic retainers to the holder body. The Holders are universal accepting Twin, Triple, Quad and Quint Retainers. As with the Tine Holders, it is a good idea to have a set of Holders for each set of Retainers for convenience.



Turf Retainers

TWIN TR2 & TR2W

Twin Turf Retainers can be used with all Twin Holders no matter which Tine is being used. One wide Retainer TR2W is required with each set, it is always fitted to extreme left of the machine as viewed from the rear. There are seven standard and one wide retainer in the model 8120 and eleven standard and one wide Retainer in the model 12180 Turf Aerator machine.



TRIPLE TR3 & TR3W

Triple Turf Retainers can be used with all Triple Holders no matter which Tine is being used. One wide Retainer TR3W is required with each set, it is always fitted to extreme left of the machine as viewed from the rear. There are seven standard and one wide Retainer in the model 8120 and eleven standard and one wide retainer in the model 12180 Turf Aerator machine.



QUAD TR4 & TR4W

Quad Turf Retainers can be used with all Quad Holders no matter which Tine is being used. One wide retainer TR4W is required with each set, it is always fitted to extreme left of the machine as viewed from the rear. There are seven standard and one wide Retainer in the model 8120 and eleven standard and one wide Retainer in the model 12180 Turf Aerator machine.



QUINT TR5 & TR5W

Quint Turf Retainers can be used with all Quint Holders no matter which Tine is being used. One wide Retainer TR5W is required with each set, it is always fitted to extreme left of the machine as viewed from the rear. There are seven standard and one wide Retainer in the model 8120 and eleven standard and one wide Retainer in the model 12180 Turf Aerator machine.



Tines & Holders

SC (spigot clamp) Tine Holders

Groundsman developed the Spigot Clamp type of mounting for a quick and secure attachment of Tine Holders to the HD (heavy duty) range of Turf Aerator machines including Tractor Mounting. This type of Tine Holder is available for mounting the following number of Tines in each Holder; two (Twin Holder) three (Triple Holder) four (Quad Holder) five (Quint Holder). A range of sockets is available depending on the holder. A socket is the hole into which the Tine is clamped, the size of socket required is given with each tine specification in the catalogue.

Full Listing is on Page 8

DB (draw bolt) Tine Holders

The Draw Bolt is the type of mounting required to attach the Tine Holders in the Medium Duty Turf Aerator model 345 MD. These are available in Twin and Triple Holders only. A range of socket sizes is available. Refer to the Tine Holder catalogue where the required socket size is given with the Tine specification.

Full Listing is on Page 8

Tubular Hollow Tines

Tubular Hollow Tines consist of taper-bore case hardened tubular steel. The core is ejected out the top of this tine. Groundsman supply these tines for 13mm (1/2") 16mm (5/8") and 19mm (3/4" jumbo) coring. They are available in standard and long length.

Full Listing is on Page 9

Side Discharge Hollow Tines

Side Discharge Hollow Tines are manufactured from high tensile hardened and tempered steel. The core with this type of tine is ejected out a slot in the side of the tine and this manufacturing process makes this tine more expensive. The advantages are its thicker wall gives it better wear resistance and it is less prone to clogging especially in the smaller core sizes. Groundsman supply these tines for 8mm (5/16") 10mm (3/8") 13mm (1/2") 16mm (5/8") and 19mm (3/4"jumbo). One standard length is available.

Full Listing is on Page 10



Solid and Needle Tines

Solid and Needle Tines are manufactured from high tensile steel which is hardened then tempered just enough to relieve any brittleness to achieve the maximum wear qualities. The taper on the working diameter is designed to minimise exit suction and thereby surface lifting.

Full Listing is on Page 11

Chisel & Star Tines

Groundsman Chisel Tines are a drop forging of high tensile steel which give them unbeatable strength and wear resistance. These are available in widths of 25mm (1") and 30mm (1 1/4"). Both can be supplied in standard or long length. Star Tines were developed as a form of spiking but with less soil displacement. In theory, the wall of the hole is subjected to less pressure and compaction with more surface area to absorb the nutrients.

Full Listing is on Page 12

Cluster Tine Heads

Cluster Tines are available in eight or ten groupings of Needle or Micro Hollow Tines. The hollow is excellent for thatch removal over-seed preparation to about 20mm 3/4" maximum depth. The needle will prick the surface to about 40mm (1 1/2") depending on density like a vertical action sorrel roller. These disposable heads are available for attachment to the machine using a Cluster Mounting Flange available for Spigot Clamp (SC) or Draw Bolt (DB) mount.

Full Listing is on Page 13

Note:

Most Tines are available in standard and long length. The Tractor Mounting machines can accept all lengths while the pedestrian are limited because of ground clearance to a maximum of 140mm (5 1/2") overall length of tine.

Cluster Mounting Flanges

Used to attach all types of Cluster Heads to Spigot Clamp (SC) or Draw Bolt (DB) mountings.

Full Listing is on Page 13

Turf Retainers

Turf Retainers are available for the Groundsman Turf Aerator range. A rack spans the width of the machine attached at either end to the roller leg. The retainers consist of impact resistant plastic rails which clamp the turf surface holding it in place during aeration i.e, spiking or hollow coring. These plastic sections are clamped into a holder and are available for Twin, Triple and Quadra Tine Holders.

Full Listing is on Page 5



DESCRIPTION : Twin Tine Holder

SPIGOT CLAMP no. SC212, SC258, SC234, SC278
 DRAW BOLT no. DB212, DB258, DB234, DB278

SOCKET SIZE : ½" 5/8" ¾" 7/8"

AERATION PATTERN : 3" x 3"(Minimum Uniform)

RECOMMENDED USE :

Generally used with the larger tines i.e. ¾" 5/8" or ½" where the wider hole spacing is desirable. Twin Holders are also useful to achieve maximum depth where conditions are very hard and compacted. The choice of tine would depend on the severity of the compaction, i.e, the finer the tine the easier it would be to achieve full penetration. Twin Holders are available in all four-socket sizes including the recently introduced 7/8" sck. for Jumbo Hollow Tines.



DESCRIPTION : Triple Tine Holder

SPIGOT CLAMP no. SC312, SC358, SC334
 DRAW BOLT no. DB312, DB358, DB334

SOCKET SIZE : ½" 5/8" ¾"

AERATION PATTERN : 2" X 2" (Minimum Uniform)

RECOMMENDED USE :

Normally used with the medium sized tines i.e, ½" or 7/16" although the smaller micro tines can be used where conditions are compacted or the pattern produced is desirable. The 1½" slit or 5/8" hollow and solid tines are generally not recommended for use in triples and certainly used only if conditions are soft and an exceptionally large amount of soil is to be removed or disturbed. This holder is available in three socket sizes therefore all tines except 7/8" socket jumbos will fit.



DESCRIPTION : Quadra & Quint Tine Holder

SPIGOT CLAMP no. SC412, SC512

SOCKET SIZE : ½" & ½"

AERATION PATTERN : 1 ½" 1 ¼"

RECOMMENDED USE :

Normally used only with the smaller tines, i.e. 3/8" and 5/16" for micro hollow and solid tining including needles all of which fit the ½" socket. The Quint Holder can also be used for over-seeding preparation or thatch removal.



DESCRIPTION : 5/8" & 3/4" Hollow Tine

PART NO : GTH58 GTH34

SOCKET SIZE : 3/4" 7/8"

OVERALL LENGTH : 4 1/2" 4 3/4"

RECOMMENDED USE :

Normally used in Twin Holders with the pedestrian range of machines. Spring and Autumn general purpose aeration of compacted areas to maximum depth. Large core size at 3" x 3" hole pattern. Moderate to severe soil removal. GTH34 Jumbo Tine is normally used on fairways or where a large amount of soil exchange is desired



DESCRIPTION : 5/8" Long & 3/4" Long Hollow Tine

PART NO : GTH58L GTH34L

SOCKET SIZE : 3/4" 7/8"

OVERALL LENGTH : 5 1/2" 5 3/4"

RECOMMENDED USE :

Normally used in Twin Tine Holders with the Groundsman model 8120 Tractor Mounted machine, however they can be used on the pedestrian range where conditions permit. Spring and Autumn general purpose aeration of compacted areas to maximum depth. Large core size at medium hole pattern (3" x 3"). Moderate to severe soil removal. GTH34L Jumbo Hollow Tine is normally used on fairways or for excessive soil exchange.



DESCRIPTION : 1/2" Hollow Tines

PART NO : GTH12

SOCKET SIZE : 5/8"

OVERALL LENGTH : 4 3/8"

RECOMMENDED USE :

Normally used in Triple Holders with the pedestrian range of machines however, they can be used in twins for compacted conditions or on harder surfaces such as Cricket tables or Tee boxes and approaches. Spring and Autumn aeration producing a medium sizes core to maximum depth, moderate soil removal.



DESCRIPTION : 1/2" Hollow Tine (Long)

PART NO : GTH12L

SOCKET SIZE : 3/4"

OVERALL LENGTH : 5 1/2"

RECOMMENDED USE :

Normally used with Groundsman model 8120 Tractor Mounted machine fitted to Triple Holders for close pattern hollow coring of Greens etc. Use on Twin Holders for harder more compacted surfaces or if the wider hole pattern is more desirable. These tines can be fitted to the pedestrian machines but preferable on a Twin Holder. Medium core size to maximum depth with moderate soil removal.



DESCRIPTION : 5/16" SD Hollow Tine

PART NO : GTSD516

SOCKET SIZE : 1/2"

OVERALL LENGTH : 4"

RECOMMENDED USE :

Normally used in Quint or Quadra Tine Holders producing a 1 3/8" x 1 3/8" or 1 1/2" x 1 1/2" hole pattern respectively and up to 2 1/2" deep. Year round aeration with thatch removal or preparation for over seeding. Dispersible miniature cores.

DESCRIPTION : 3/8" SD Hollow Tine

PART NO : GTSD38

SOCKET SIZE : 1/2"

OVERALL LENGTH : 4 3/4"

RECOMMENDED USE :

Normally used in Quadra or Quint Tine Holders but can also be used on Triples for harder more compacted surfaces or if the wider hole pattern is desirable. Produces a small core to a maximum depth of about 3". Minimal disruption coring for surface compaction relief or thatch removal. Also effective for over-seeding.

DESCRIPTION : 1/2" SD Hollow Tine

PART NO : GTSD12

SOCKET SIZE : 5/8"

OVERALL LENGTH : 5 1/2"

RECOMMENDED USE :

Normally used in Triple holders for Greens if conditions are not too compacted. Use Twin Holders for Tee boxes and approaches etc. or Cricket tables where conditions are harder and maximum depth is desirable. Medium soil removal to depths of 3 1/2" to 4" maximum.

DESCRIPTION : 5/8" & 3/4" SD Hollow Tine

PART NO : GTSD58 GTSD34

SOCKET SIZE : 3/4" 7/8"

OVERALL LENGTH : 5 3/4" 6 3/8"

RECOMMENDED USE :

Normally used in Twin Holders producing a 3" x 3" hole pattern at depths of 4" to 4 1/2" maximum. Spring and Autumn general purpose aeration of compacted areas. Large core size with moderate to severe soil removal. GTSD34 Jumbo Tine is normally used on fairways or on areas where extreme soil exchange is desired.



DESCRIPTION : 5/8" Solid Tines

PART NO : GTS58 GTS58L GTS58XL (Tractor Mounted only)

SOCKET SIZE : 5/8" 5/8" 5/8"

OVERALL LENGTH : 5 1/2" 6 1/2" 7 3/4"

RECOMMENDED USE :

Normally used in Twin Tine Holders. Soft to medium areas in need of drainage. Maximum depth spiking producing quite a large hole at 3" centres. Please note: Not recommended for compacted surfaces.

DESCRIPTION : 1/2" Solid Tine

PART NO : GTS12 GTS12L GTS12XL (Tractor Mounted only)

SOCKET SIZE : 5/8" 5/8" 5/8"

OVERALL LENGTH : 5 1/2" 6 1/2" 7 1/2"

RECOMMENDED USE :

Normally used in Twin Holders for maximum penetration in compacted surfaces. General purpose spiking for areas in need of aeration and drainage.

DESCRIPTION : 7/16" Solid Tine

PART NO : GTS716 GTS716L GTS716XL (Tractor Mounted only)

SOCKET SIZE : 1/2" 1/2" 1/2"

OVERALL LENGTH : 5" 6" 7"

RECOMMENDED USE :

Normally used in Triple Holders (1/2" sck.) for year round spiking and surface drainage with minimal surface disruption. This tine can also be effective in Twin Holders for heavily compacted areas.

DESCRIPTION : 3/8" Solid Tine

PART NO : GTS38 GTS38L

SOCKET SIZE : 1/2" 1/2"

OVERALL LENGTH : 4 3/4" 5 3/4"

RECOMMENDED USE :

Normally used in Quadra Holders. The 3/8" solid tine is the thickest in the micro-tine category. Durable yet fine enough to perform year round aeration and improve drainage without disturbing play.

DESCRIPTION : 5/16" Needle Tine

PART NO : GTS516 GTS516L

SOCKET SIZE : 1/2" 1/2"

OVERALL LENGTH : 4 1/2" 5 1/2"

RECOMMENDED USE :

Normally used in Quint Tine Holders for close pattern spiking throughout the summer. Regular use is recommended, especially effective immediately before treatments such as fertilisation.

DESCRIPTION : 1/4" Needle Tine

PART NO : GTS14 GTS14L

SOCKET SIZE : 1/2" 1/2"

OVERALL LENGTH : 4 1/2" 5 1/2"

RECOMMENDED USE :

Normally used in Quint Tine Holders for summer aeration on fine turf with little trace on the surface. Use often for maximum effect especially throughout the growing season. Also available in clusters.



DESCRIPTION : 1" Chisel Tine
PART NO : GTSL1 GTSL1L
SOCKET SIZE : ½" ½"
OVERALL LENGTH : 5 1/8" 6 1/8"

RECOMMENDED USE :

Normally used in Twin for aeration and root pruning on fine turf to 4 ½" & 5 ½" depth. This form of slitting leaves no surface gash and is not prone to opening during dry spells. A popular choice for Winter or year round aeration with little or no surface disturbance.

DESCRIPTION : 1 ½" Chisel Tine
PART NO : GTSL112
SOCKET SIZE : 5/8"
OVERALL LENGTH : 5 5/8"

RECOMMENDED USE :

Only use in Twin Holders for 3" x 3" pattern. Soft to medium areas for up to 5" deep slit pattern and root pruning. Groundsman chisel tines leave a close pattern stitched effect which is not prone to opening during dry spells. Polish on approach before going on fine turf.

DESCRIPTION : Star Tines
PART NO : GTST12 GTST12L
SOCKET SIZE : ½" ½"
OVERALL LENGTH : 5 ½" 6 ½"

RECOMMENDED USE :

Normally used in Triple Holders. Has the hole surface area of much larger tines with little trace on the playing surface. Ideal playing season aeration to maintain oxygen, water and chemical movement. Enhances root density. Recommended by many agronomists.

DESCRIPTION : Star Tines
PART NO : GTST58 GTST58L
SOCKET SIZE : 5/8 " 5/8 "
OVERALL LENGTH : 5 ½" 6½"

RECOMMENDED USE :

Normally used in Twin Holders. Has the hole surface area of much larger tines with little trace on the playing surface. Ideal playing season aeration to maintain oxygen, water and chemical movement. Enhances root density. Recommended by many agronomists.

Please Note

The Tines and fittings in this catalogue have been selected because they have proven to be the most popular and effective. However, Groundsman Industries will manufacture special tines and fittings to suit your requirements. To discuss this please contact Billy Warke on (Tel) 028 276 67049 (Fax) 028 276 66855 or by (Email) bwarke@groundsmanindustries.co.uk Visit our website : www.groundsmanindustries.com for more information



DESCRIPTION : Cluster of 5/16" or 3/8" Hollow Tines
PART NO : 8SD516 8SD38
**AERATION PAT-
 TERN :** 1 1/2" x 1 1/2" (64 - sq./ft.)
 (38mm X 38mm)
DEPTH RANGE : 1/2" - 2 1/2"
RECOMMENDED USE :



Use for very close pattern Micro Hollow Tining at medium to shallow depth to enhance surface drainage while relieving surface compaction. Very effective at shallow depth for thatch removal and in preparation for over-seeding.

DESCRIPTION : Cluster of Eight Solid Tines
PART NO : 8S14 8S516
SPIKE DIAMETER : 5/16" & 1/4" (needles)
**AERATION PAT-
 TERN :** 1 1/2" X 1 1/2" (64 - sq./ft.)
 (38mm X 38mm)
MAX DEPTH : 3"
RECOMMENDED USE :



Fast ground coverage for close pattern spiking throughout the Summer and just before treatments such as fertilisation to encourage deeper rooting. No surface disruption.

DESCRIPTION : Cluster of Ten Solid & Hollow Tines
PART NO : 10S516 10SD516
SPIKE DIAMETER : 5/16"
**AERATION PAT-
 TERN :** 1 1/4" X 1 1/4" (100 - sq./ft.)
 (30mm X 30mm)
DEPTH RANGE : 1/4" - 1"
RECOMMENDED USE :



Use for very close pattern Micro Hollow Tining at shallow depth for thatch removal and in preparation for over-seeding.

DESCRIPTION : Cluster of Ten Solid Needle Tines
PART NO : 10S14
SPIKE DIAMETER : 1/4"
**AERATION PAT-
 TERN :** 1 1/4" X 1 1/4" (100 - sq./ft.)
 (30mm X 30mm)
DEPTH RANGE : 1" - 2"
RECOMMENDED USE :



Produces precision depth Needle Tining at a very close pattern for a Sorrel Roller effect for surface drainage or over-seeding.

DESCRIPTION : Cluster Head Mounting Flange
MOUNT TYPE : Spigot-clamp The HD Range Draw-bolt The MD Range
PART NO : GSCMF GDBMF
RECOMMENDED USE :



Used for mounting Cluster Heads to machines accepting the spigot-clamp & Draw-Bolt type fitting.

Core Collection

CORE AND COLLECT IN ONE PASS.

Models: FCC8 & FCC12

This patented attachment is available for the Groundsman Tractor Mounting Turf Aerator models 8120CTM and 12180TM. Cores are dumped automatically when the machine is raised. A series of soil or core piles will be left on the edge of the green or aerated area. The Collector has the capacity to collect these piles into one collective pile, eg to a selected spot away from play. This attachment can save many hours of manual work or a follow up operation with heavy cumbersome equipment. It is clean and efficient with over 60% of the cores entering the collector without touching the ground. The remainder are scooped cleanly from the surface by a series of platelets which follow the contours acting like shovels.



Models: TCCTM7C FCCTM9C FCCTW9

The Flexblade Core / Soil Collector is now also available as a stand alone implement on a three point linkage frame or for mounting on Turf Vehicles such as a Toro Workman. Suitable for core or linear aeration soil. The implement can be driven rapidly over the surface without effecting collection making it extremely efficient. The cores or soil are scooped cleanly from the surface by a series of platelets which follow the contours acting like shovels. This operation will not be hindered by the cores or soil getting wet or driven over, the flexblade will scoop them cleanly from the surface without break-up keeping the aeration holes open. These piles can then be collected into one pile away from play. Can be used on fairways and football pitches as well as fine turf.



Performance Chart

- FCCTM7 up to 16km (10miles) per Hour up to 22,000m³ (20,000sq/yds)
- FCCTM9 up to 16km (10miles) per Hour up to 27,600m³ (25,400sq/yds)
- FCCTW9 up to 16km (10miles) per hour 27,600m³(25,400sq/yds) 27,600m³ (25,400sq/yds)



Turf multi Cutters

Turf multi Cutter Model TCSR B

The new TCSR B Turf Cutter has been specifically developed by Groundsman Industries for the Hire and Landscaping Trades. The machine uses the same Toothed Belt Crank Drive and Blade Mechanism as the extremely successful TCDRB but the price tag has been trimmed by removing the features which are not important to this industry such as micro fine depth adjustment.



Turf multi Cutter Model: TCDRB

The Groundsman model TCDRB is a four wheel drive precision Turf Cutter with exceptional traction and operator comfort. The machine has been designed for precision cutting of turf for relaying. Blades are available for cutting 12, 14, 16 and 18 inch wide sod and a Guillotine Attachment is available. The rear mounting blade position gives easy access and visibility for cut alignment and the cross-blade is positioned directly under the rear wheels for consistent depth of cut in rolling terrain with out of work ground clearance. Centre mounting Mole Drain, Soil De-compactor and Trench Cutting Blades to 12cm (5") working depth give the TCDRB even more versatility.



Turf multi Cutter Model: TCDRB fitted with TCDGCO

A Guillotine Attachments can be fitted to the Groundsman TCDRB to chop the turf to preset lengths for relaying. This compact attachment picks up the drive from an auxiliary sprocket on the turf cutter crank-shaft and the turf lengths are measured by an infinitely adjustable meter wheel which runs along-side the rear axle on the Turf Cutter. The attachment is complete with a safety frame and front counter weights which maintain perfect balance for the operator. Guillotine blades are available for 12, 14, 16 and 18" wide cuts

Full Listing is on Page 19



Turf multi Cutter Model: TCHYD

The Groundsman model TC HYD Turf multi Cutter is the latest model to be added to the Groundsman Turf Multi Cutter range. This model was developed initially to insert irrigation pipe to a depth of up to 15cm in a one pass operation using the Groundsman patented Wedge Blade system and pipe or cable reel attachment. This high traction work horse is fitted with a 9HP engine and has a Hydrostatic Ground Drive giving variable speed forward reverse and rapid transport. (Continued over)



Turf multi Cutters

Model: TCHYD Continued.

The Cutter Blade is engaged independently by a disc clutch. This machine lends itself to a host of operations and blade configurations to perform many operations including Trenching as well as the regular Turf Cutting functions.

The Trenching function requires a very high traction to weight ratio. This has been achieved by incorporating a hydrostatic drive which allows the operator much more control to feed the power to all four wheels without slip or spin. Wheel weights can be attached to the front axle to increase grip without adversely affecting the operator's ability to manoeuvre the machine. A differential has been incorporated for easy turning.

In addition to accepting the full range of Groundsman Turf Cutter Blades, a Wedge Blade Trenching System has been developed specifically for this machine. This system can insert Pipe or Cable from an attached Reel or Materials from a Hopper to a depth of 120mm (5") with minimum surface disruption. A spring loaded vibrating roller is available to close the trench and level the surface.

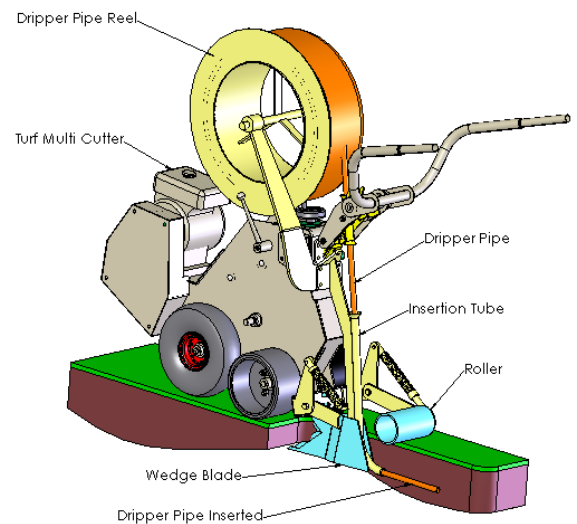

DRIP FEED IRRIGATION INSERTION USING THE WEDGE BLADE

To Fit TC HYD Turf multi Cutter

Wedge Displacement Blade

Part No: TCWB34D (34mm with disc)
TCWB34 (34mm no disc)

The Wedge Insertion Blade cuts a single slit in the ground which is separated by the wedge portion of the blade to a width up to 40mm (1 1/2") to enable the insertion of Pipe, Cable or materials such as Gravel or Sand down to 5" depth. The traction requirement of this blade largely restricts its use to the TCHYD Hydro Drive machine. Blades only versions are available with no cutter disc. Displacement (trench width) available up to 40mm maximum.

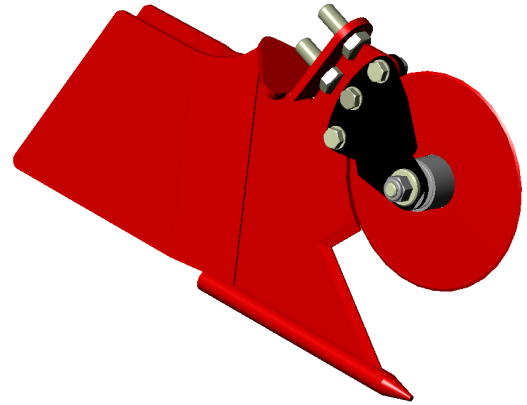

TC C RIA

Cable Reel Insertion Attachment

Part No: TCCRIA

The model TC C RIA Reel Insertion Attachment is available for use on the Groundsman model TCHYD Turf Trencher Multi Cutter. The attachment was developed to insert cable to a depth of up to 15cm for purposes such as cable TV installations on caravan parks in a one pass operation using the patented soil displacement Wedge Blade. The attachment comes complete with a quick detachable pipe reel and mounting bracket. A vibrating roller closes over the trench on top of the inserted pipe. The whole operation is fast and hardly visible on the surface when complete and can be used for a whole range of applications.

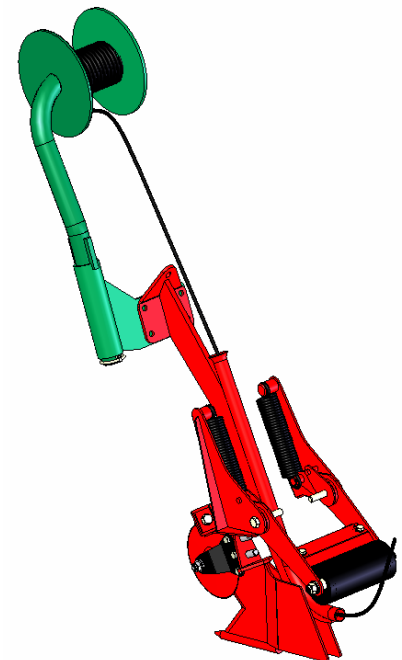

TC P RIA

Pipe Reel Insertion Attachment

Part No: TCPRIA

The model TC P RIA Reel Insertion Attachment is available for use on the Groundsman model TCHYD Turf Trencher Multi Cutter. The attachment was developed to insert pipe such as dripper-line irrigation pipe to a depth of up to 15cm in specialist landscaping projects a one pass operation using the patented soil displacement Wedge Blade. The attachment comes complete with a pipe reel and mounting bracket which incorporates an adjustable over-run brake. A vibrating roller closes over the trench on top of the inserted pipe. The whole operation is fast and hardly visible on the surface when complete and can be used for a whole range of applications.

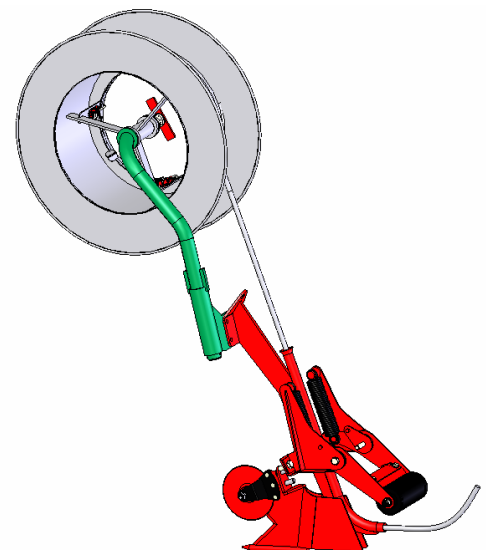

TCDRB & TCHYD Attachments

Turf Cutting or Sod Blades

Part No For DRB & HYD

Blades: TCDB 12,14,16, 18

Wheels: TCDBW 12,14,16, 18

Groundsman Industries manufacture a range of Sod or Turf Cutting blades for 30cm (12") 35cm (14") 40cm (16") 45cm (18") wide cuts. These blades are manufactured from durable high tensile steel with excellent wear qualities. The patented design of side knives give exceptionally clean cut edges and the cross section of the bottom is formed to reduce bowing and the blade cuts under the wheel for more precision especially in the wider and thin cuts.

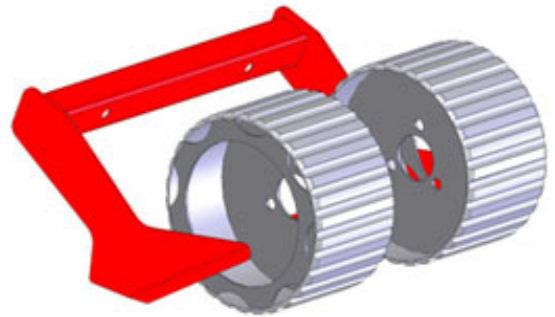

Available for models TCDRB & TCHYD

De-compactor Blade

Part No: TCSP3 TCSP5

De-compactor Blades have been developed by Groundsman Industries to cut a single slit in the ground down to 12cm (5") depth. The tail of the blade is offset to shift and disturb the soil at the bottom of the slit under the surface to cultivate and relieve compaction. This blade is attached to the rear centre mounting point on the Turf Cutter machine.



Available for models TCDRB & TCHYD

Mole Drain Blade

Part No:TCMD3 TCMD5

Mole Drain Blades work in the same way as the De-compactor blade cutting a single slit in the ground. A 16mm (5/8") diameter bullet point at the lower edge of the blade puts a drain 25cm (5") under the surface.



Available for models TCDRB & TCHYD

Trench Blade

Part No: TCTR4 TCTR5

Trench Blades are available to cut trenches from 3cm to 30cm wide and up to 15cm deep. The profile of the side knives have been specially formed to minimize the surface area and the gap expands behind the cutting edge to enhance the through flow of turf. This is especially helpful for the narrower cuts. This blade can be fitted to the TCDRB and TCHYD machines. A trench blade is available for the TCSR to a maximum depth of 8cm.

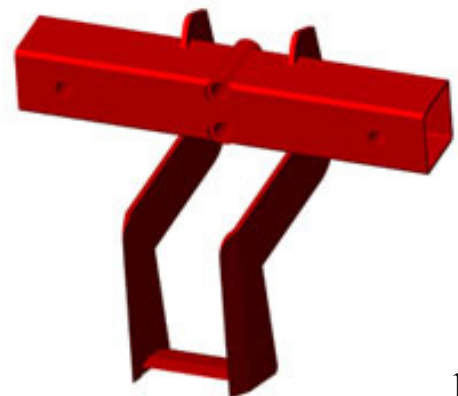

Available for models TCDRB & TCHYD

TC HYD & DRB Attachments

Guillotine Attachment

Part No: TCHGCO TCDGCO
Blades: TCC012 TCC014
 TCC016 TCC018

A Guillotine Chop-off Attachment can be fitted to the Groundsman models TCDRB or TC HYD Turf Multi Cutters to chop the turf to preset lengths for relaying. This compact attachment picks up the drive from an auxiliary sprocket on the Turf Cutter crank-shaft and the turf lengths are measured by an infinitely adjustable meter wheel which runs along-side the rear axle on the Turf Cutter. The attachment is complete with a safety frame and front counter weights which maintain perfect balance for the operator. Guillotine blades are available for 12, 14, 16 and 18" wide cuts.



Available for models TCHYD & TCDRB

TCDRB Blades

Revetting Blade

Part No: TCRV12 TCRV14
 TCRV16 TCRV18

Revetting or centre knife blades mount in exactly the same way as the standard sod blades. They were developed to cut narrow multiple strips of turf for revetting or sod wall building such as when creating a golf bunker. Revetting blades can have one or more centre knives and are available in all blade widths i.e, 12, 14, 16 and 18" cuts. A single centre knife on a 12" (30cm) blade will produce two 6" (15cm) sod strips up to 3" (7cm) thick.



Available for models TCHYD & TCDRB

TCSRBlades

Sod blades

Part No: TCSB12 TCSB14
 TCSB16 TCSB18

Sod Blade for 12" (30cm) 14" (35cm) 16" (40cm) and 18" (45cm) wide cuts are available for the TCSRBlade Turf Multi Cutter. Revetting or centre knife blades are also available in all four widths. Out of work ground clearance does not permit the use of the mole, de-compaction or trenching blades on the TCSRBlade Turf Cutter .

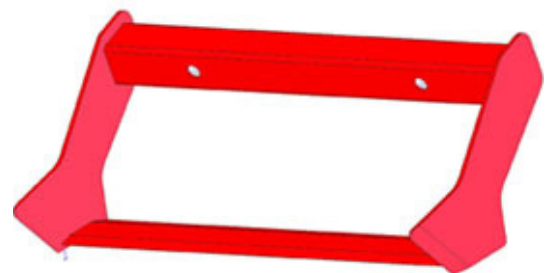

Available for model TCSRBlade

